

## CIRCULAR KNIVES. SPACERS.

### Type ZR

Outer-Ø (D) mm	Inner-Ø (d) mm
46	30
60	40
77	45 / 60
80	45 / 60
105	80 / 90
130	100 / 120
150	100 / 120
200	150 / 180
250	200

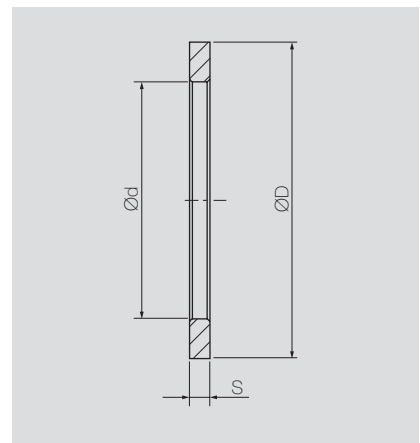
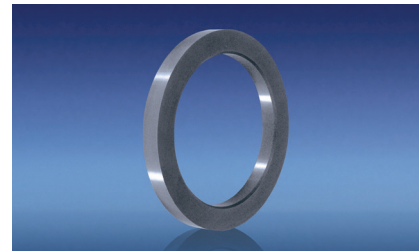

**Total thickness (S): from 0.1 mm**

**Other dimensions and materials on request.**

#### Standard material:

chrome alloyed tool steel (1.5 % Cr)

#### Benefits:

- | exact manufacturing tolerances
- | DIENES precision grinding "CONTROLLEUR"
- | usable for different machine types

**DIENES also manufactures suitable cutting rings, top and bottom knives, knife holders as well as manual, semi-automatic and automatic slitting systems.**