

Information on existing machine:

Make:	
Type:	

Type of design (please tick):

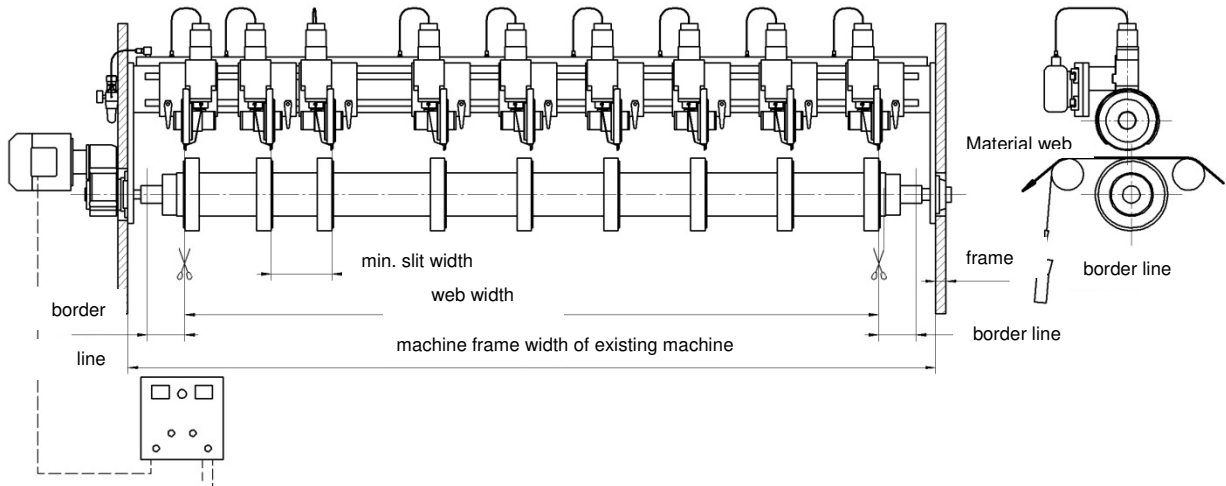

Option A: slitting system with bottom knives mounted on shaft

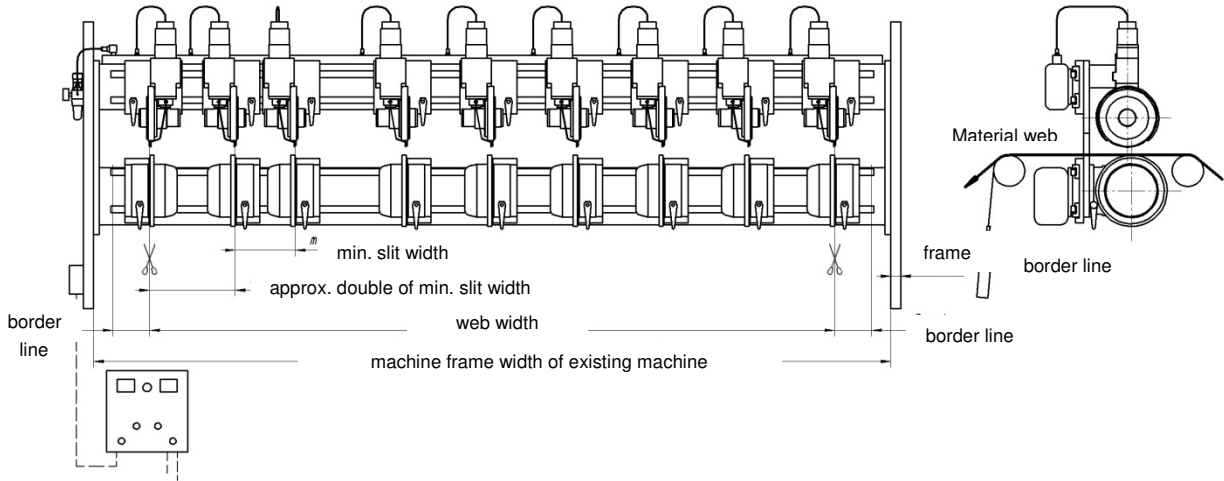

Option B: slitting system with bottom knife motors

